



# UTS-2 INVISIBLE WIRELESS CHARGER

Quick start guide Setup and Installation  
on your Tristone Solid Surfaces



Developed & manufactured by:





## Quick start guide

### Kew Lab UTS-2 Invisible Wireless Charger

Kew Labs UTS -2 Invisible wireless chargers are designed to be installed under non-metallic materials to turn any surface into a hidden wireless phone charger.

UTS-2 Invisible Wireless Charger (SKU: UTS-2) has been tested and approved for use on your Tristone surfaces.

#### **Product Features:**

- Hidden phone charging keeps surfaces tidy.
- 8-12mm (0.31"-0.47") long distance charging capability.
- Apple® and Samsung® fast charge protocols
- Patented Intelligent Power Communication (IPC™) Technology.
- USB-C Power.

#### **Recommended Usage:**

- Kitchen countertops.
- Kitchen Islands.
- Furniture and bar tops.

# Installation Thickness Guidelines

Surface (mm)	Main Application	Compatibility	Routing Requirement
12+	Countertops & Furniture	Yes	No
20+		Yes	Route to 12 mm[1]

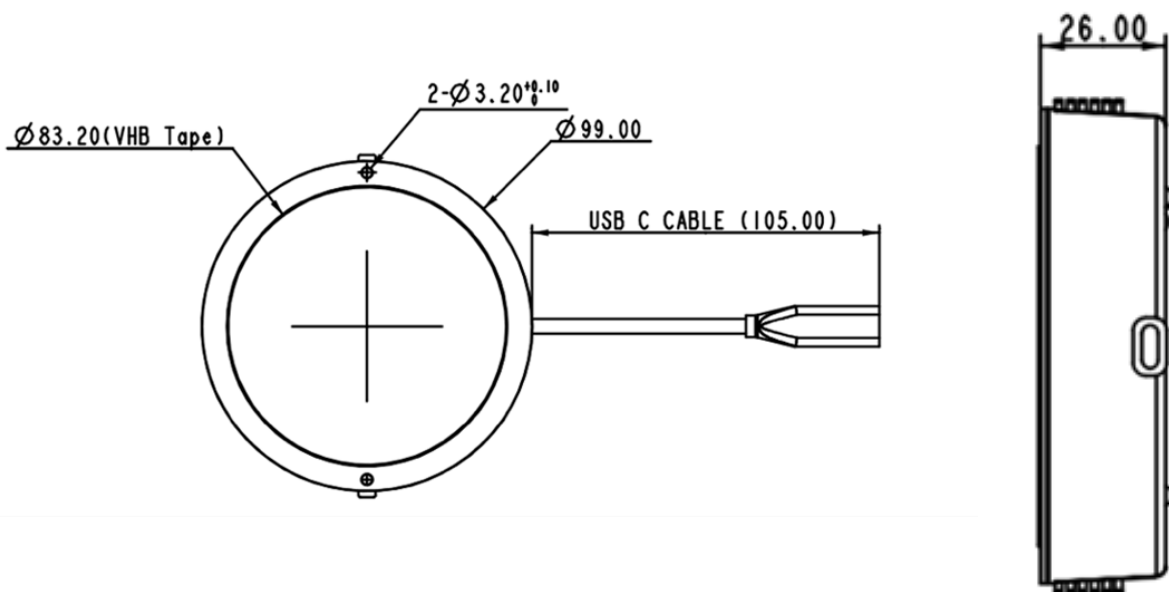

# Specifications

Item	UTS-2 Specifications	
Product SKU & Variations	Model Name	Description
	UTS-2-US	w/ US plug
	UTS-2-EU	w/ EU plug
	UTS-2-AUS	w/ AUS plug
	UTS-2-UK	w/ UK plug
Input Power	DC 12V/2A	
Output Power	Max 20W	
Standby Power Consumption	0.35W	
Charging	Apple 7.5W, Samsung 10W, Standard 5W Qi wireless charging	
Material Compatibility	Tristone Solid Surfacing	
Devices Compatibility	All Qi wireless charging enabled devices.	
Unit Size / Weight	ø99cm x 26mm (H) – (3.9”) / 197g Ø 3.9” x 1.02” (H) / 6.95 oz	
Effective charging distance	Model	Charging Distance
	UTS-2	8mm-12mm (0.31” – 0.47”) – to ensure universal compatibility. Does not work below 8mm.
Frequency	123K-185KHz	
Accessory	Multi design charging position sticker, USB-C adapter er 12V/2A, USB-C cable (1.5m 4'11”), cable management clips, screws, double sided tape (pre-fixed), alignment tool.	
Fixing Method	3M double sided tape – screws (provided)	
Protection	OPP – Overpower Protection OTP – Over temperature Protection OVP -Over Voltage Protection UVP – Under Voltage Protection FOD – Foreign Object Detection	
Safety Certificates	FCC, CE, IC	

# UTS-2 Invisible Wireless Charger Installation Instructions

1. Cut hole in surface – ensure the opening is big enough to be able to remove charger if needed.
2. Ensure power is available to charger in the surface.
3. Mount charger using tape provided and plug in.
4. Calibrate the center coil position with the alignment tool provided.
5. Place the indicator sticker under the center of the alignment tool.
6. Place center of phone on center of sticker.

## Video Installation Tutorial:

Kitchen Installation video:

<https://www.youtube.com/watch?v=2zz1UkH5SIY&t=75s>



# Design Tips

Aligning the charging position – Use phone indicator on charger as center charging position.

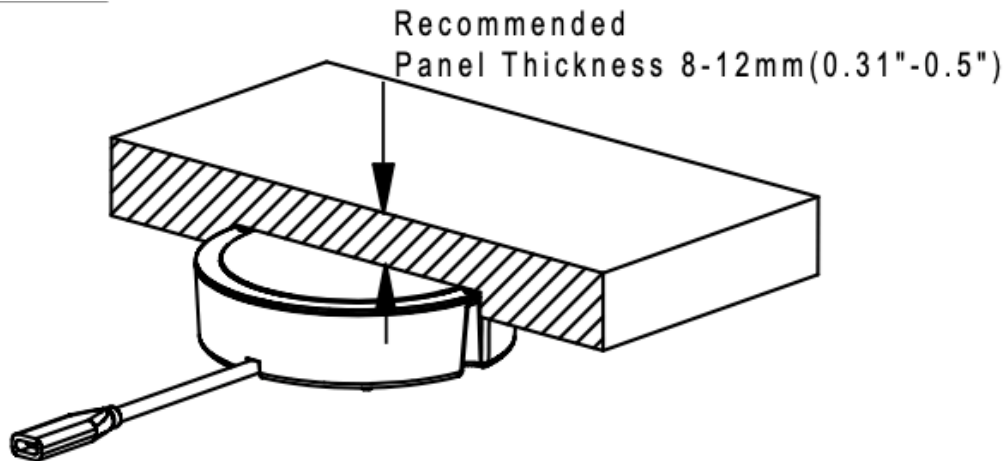

## Design Tips:

- Ventilation Allowances - Wireless charging naturally produces a small amount of heat in both phone and charger. Do not direct cover UTS-2 vent and leave at least 5cm (2") clearance.
- Heat Proximity - UTS-2 should not be located within 20cm (8") of a heat source such as hobs.
- Cut-outs proximity – UTS-2 charger and milling must not be located within 15mm (6") of a cut out or another milling.
- Water Protection – UTS-2 is not waterproof so should be located with adequate protection or distance from water sources like sinks.
- High temperatures – high environmental / room temperature affects wireless charging performance – avoid mobile phones charging in direct sunlight or temperatures exceeding 30c (86f).

# Guidelines

## Installation and setup help:

- Ensure charger is set to correct setting in 'installation thickness table'
- Phone placement tip – Align center of phone with charging indicator.
- Re-connecting your phone - It can take 2-3 seconds for a phone to connect once placed on the charger. Do not immediately move the phone if it does not connect when placed down.

Download full installation instructions and technical drawing:  
[www.kewlabstech.com/uts-2install](http://www.kewlabstech.com/uts-2install)

## Enquiries:

For project, purchasing and installation enquiries:

Please email [info@kewlabstech.com](mailto:info@kewlabstech.com)

Dealer portal registration: [www.kewlabstech.com/register](http://www.kewlabstech.com/register)

For product support and aftercare:

Please email [support@kewlabstech.com](mailto:support@kewlabstech.com)

---

## DISCLAIMERS:

- The equipment UTS-2 Invisible Wireless Charger is developed and manufactured by Kew Labs Tech, and any liabilities and warranties related to the equipment are on sole responsibility of the manufacturer.
- Any electrical installation should be done following local codes and regulations. Tristone UK Limited will not be held liable for any damages, losses or injuries associated with the installation and/or use of the UTS-2 Invisible Wireless Charger with Tristone Solid Surfaces.